

Climber GRATER HH1H00-012

Age group:
6 - 15 years



Number of users:



Dimensions of construction:

l= 1,50 m
w= 1,50 m
h= 2,50 m



Risk of fall: 2,50 cm



ČSN EN 1176-1 ed. 2 : 2018



Impact material suitable for the risk of fall
up to 3m - 34 m² 

- material: wood: robinia / oak
- fasteners: galvanized steel
- PP ropes net with steel core

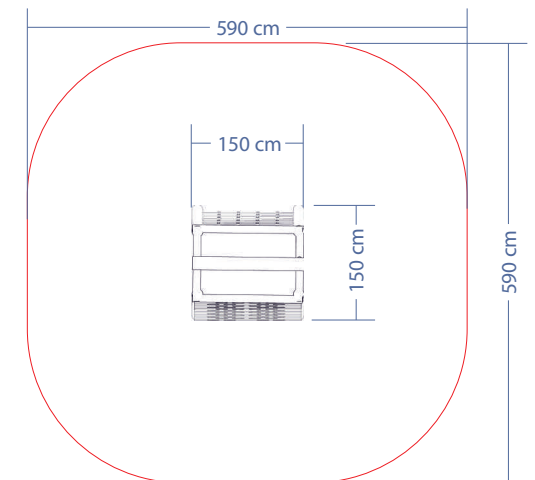
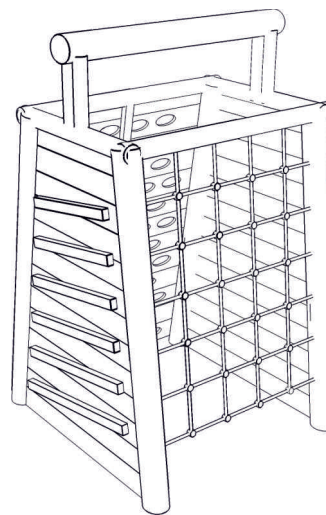

Hřiště hrou s.r.o
Sobotecká 810, Turnov
511 01, Česká republika



(+420) 7 33 141 242
info@hristehrou.cz
www.hristehrou.cz