

Installation Instructions

Surface Fixed Calypso Quatro Post Page 1 of 3



Instrument Components:

-  x8
M6x20 Security Screw
-  x2
M6 Saddle Strap
-  x4
M6 Square Nut
-  x2
Beater Holder

Metric Conversion:
1510mm/ 59"
1.5m/ 59"

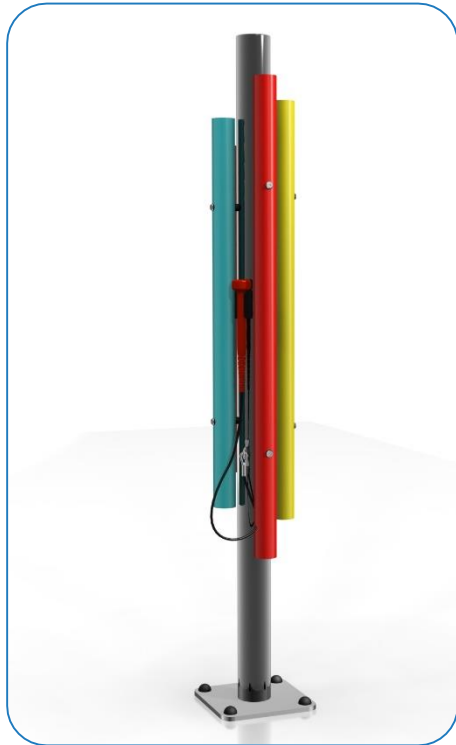

Weight of heaviest part 7.5kg

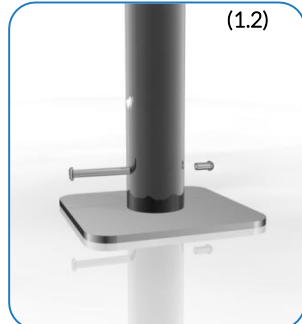

1. Instrument will arrive on site fully assembled. **(1.1)**
(See Assembly Guide)

2. Attach Surface Fixing posts to legs **(1.2)** (See Ground Fix Post Installation Sheet)

3. **Locate Plate** in desired location and mark holes to fix to desired surface.



4. Fix to Surface using recommended ground anchors not supplied

5. Make sure all fixings are covered and secure using cover caps provided

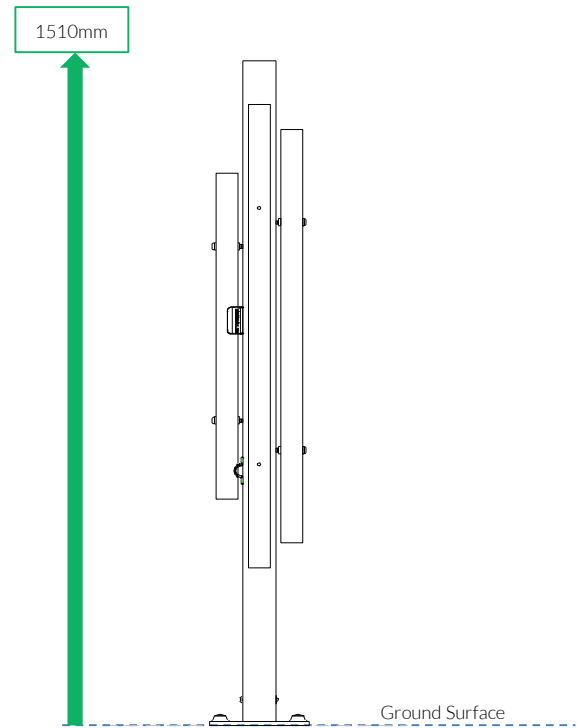
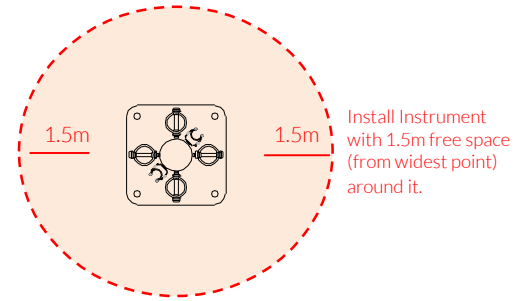
6. Attach the holders, beaters and the saddle straps on side of the post. **(1.3)**



Surface Fix Components:

-  x1
-  x1

Spares available from percussionplay.com or from your local distributor

14 Kg

Tools:

TX 30 Driver Bit x1 TX 45 Driver Bit x2

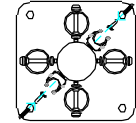

Surface Fixed Calypso Quatro Post Page 2 of 3



Instrument Components:

- x8
M6x20 Security Screw
- x2
M6 Saddle Strap
- x4
M6 Square Nut
- x2
Beater Holder

Thread Lock Solution
Required (Not Supplied)

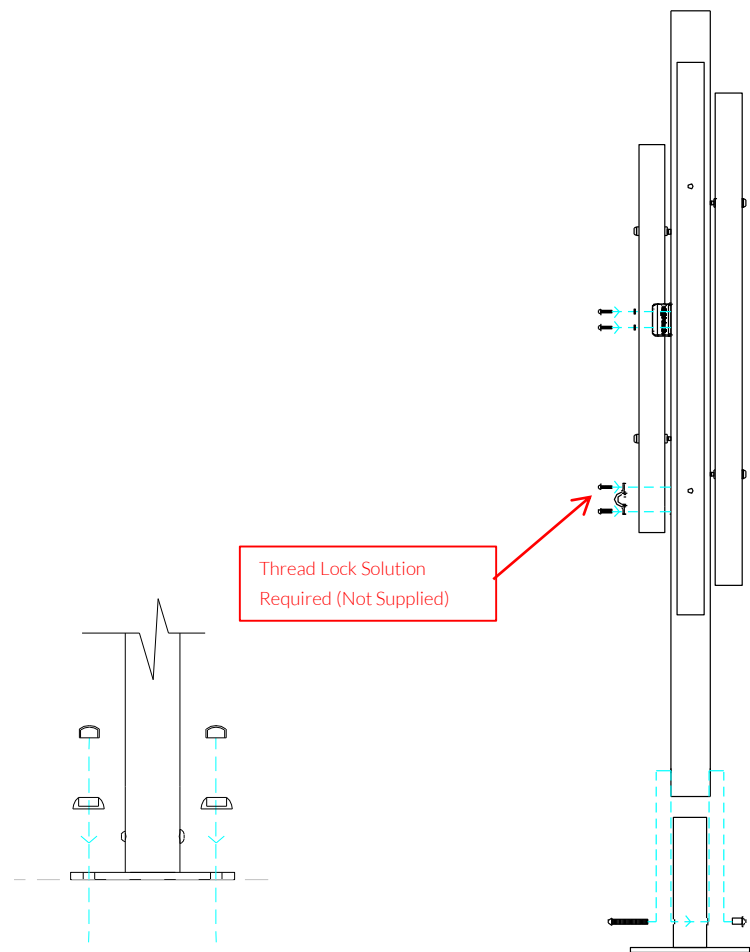

COMPONENTS LIST:

- 2 Part Cover Cap X4
- Saddle Strap X2
- M6x20 Pin torx X8
- M10x70 Pin torx X1
- M10 Barrel Nut Pin torx X1
- M6 Square Nut X4
- Beater Holder X2

Pair Small Red Beaters X1

Surface Fix Components:

- x1
- x1

Surface Fixed

 Calypso Quatro Post

 Page 3 of 3



Components:



x1

M10 Barrel Nut



x1

M10x70 Security Screw

Thread Lock Solution

 Required (Not Supplied)

1

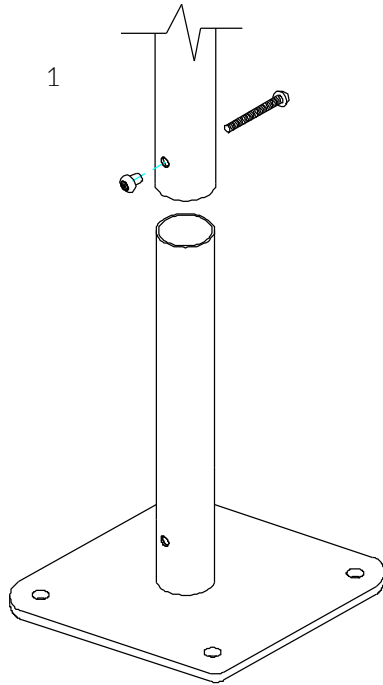

Locate the Surface fix

 Plate into the leg of the

 instrument.

2

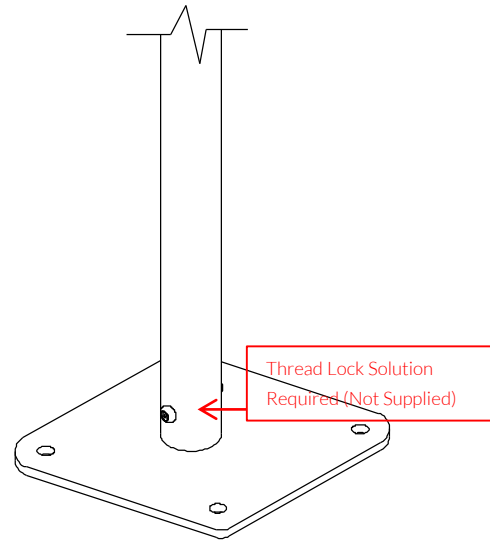

Fix instrument to Surface

 fix plate using M10 bolt

 and Barrel Nut and use

thread locking solution

 to prevent fixings working

 loose.

3

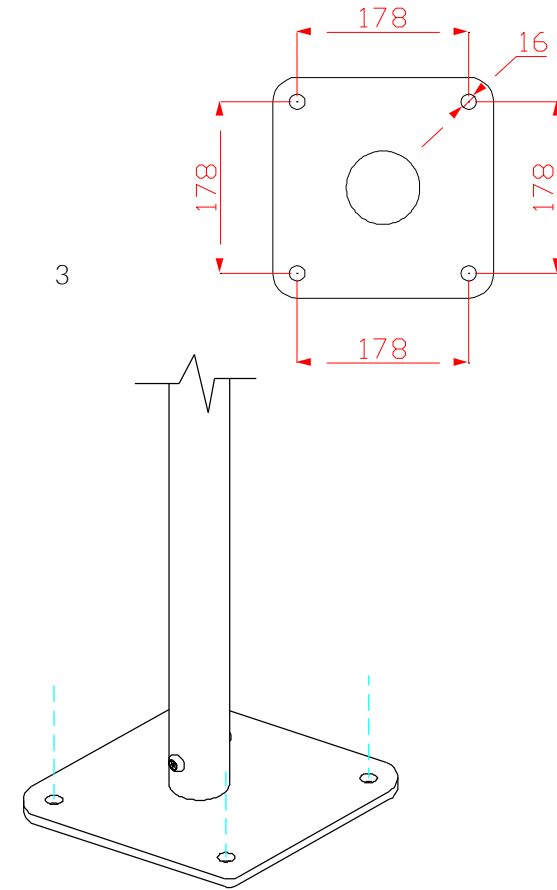

Fix Surface Plate to the

 ground surface **Ground

 Anchors Not provided**

 cover fixings with caps

 provided



MADE IN BRITAIN

BSEN 1176